

# HAND DRYERS



- Overall stainless steel food grade 304 satin finish
- IP34 protection
- Washable cleaning



**Water from hands is collected**  
No hazardous water waste on the floor



**Brushless motor DC**  
Complete closed structure to protect brushless motor and stainless steel rotor



**PCB**  
Intelligent detection voltage and temperature



**Can be washed and disinfected**



**HEPA + flannelette**  
Blocks 99.95% of 0.3  $\mu\text{m}$  particles  
Flannelette can be washed for repeated use.



**Removable water tank**  
With external valve for easy emptying



**11.114**

material: 304 stainless steel  
finish: satin

Voltage	220–240V	Noise level	<60dB
Frequency	50/60Hz	Protection level	IP34
Total power	2200W	Air temperature(10cm distance/20°C)	50°C
Motor Power (DC brushless)	700W	Drying time	5–10s
Heating element power	1500W	Air Velocity	95m/s
Cover thickness	1mm	r.p.m.	19000–20000
Weight	13kg	Automatic disconnection	25 seconds

\*Note: technical data is suitable for machine with brushless motor.



**11.101**

material: ABS  
finish: white



**11.101.B**

material: ABS  
finish: black



**11.102**

material: ABS  
finish: silver grey

Voltage	110–240V	Noise level	<72dB
Frequency	50/60Hz	Protection level	IPX4
Total power	1650–2050W	Air temperature(10cm distance/20°C)	50°C
Motor Power	750W	Drying time	9–12s
Heating element power	900–1300W	Air Velocity	95m/s
Weight	11kg	r.p.m.	20000
Electrical Isolation	class I	Automatic disconnection	25 seconds

\*Note: technical data is suitable for machine with brushless motor.

# HAND DRYERS



**11.103**

material: ABS  
finish: white



**11.104**

material: ABS  
finish: silver grey

Voltage	110–240V	Noice level	< 85dB
Frequency	50/60Hz	Protection level	IPX1
Total power	1800W	Air temperature(10cm distance/20°C)	50°C
Motor Power	750W	Drying time	9–12s
Heating element power	1050W	Air Velocity	75m/s
Weight	10kg	r.p.m.	11000–20000
Electrical Isolation	class I	Automatic disconnection	30 seconds



**11.109**

material: ABS  
finish: white



**11.110**

material: ABS  
finish: silver grey

Voltage	110–240V	Noice level	<68dB
Frequency	50/60Hz	Protection level	IPX4
Total power	1300–1800W	Air temperature(10cm distance/20°C)	50°C
Motor Power	500–700W	Drying time	9–12s
Heating element power	800–1100W	Air Velocity	85–105m/s
Weight	7kg	r.p.m.	21500
Electrical Isolation	class I	Automatic disconnection	30 seconds



11.23x series

- 11.231 ABS
- 11.232.W cast iron
- 11.232.B cast iron
- 11.233.B 304 stainless steel
- 11.233.S 304 stainless steel



11.24x series

- 11.241 ABS
- 11.242.W cast iron
- 11.242.B cast iron
- 11.243.B 304 stainless steel
- 11.243.S 304 stainless steel



11.25x series

- 11.251 ABS
- 11.252.W cast iron
- 11.252.B cast iron
- 11.253.B 304 stainless steel
- 11.253.S 304 stainless steel

**COMPONENTS & MATERIALS**

- The cover fixed to the base with four vandal-proof lock screws and a special holder.
- Universal brush motor incorporating a safety thermal cut-off.
- Aluminium centrifugal double inlet fan wheel.
- Element incorporates a safety thermal cut-off.
- Selective detection of fixed targets and system of automatic disconnection after 60 seconds of continuous use.
- Electronic infrared detection sensor. Detection distance adjustable by potentiometer(5-20cm).

Voltage	110-240V	Protection level	IPX1
Frequency	50/60Hz	Air temperature(10cm distance/20°C)	60°C
Total power	1800W	Drying time	10-15s
Motor Power	550W	Air Velocity	85m/s
Consumption	7.8A	r.p.m.	20000
Noice level	< 78dB	Automatic disconnection	30 seconds

# HAND DRYERS



**11.221.W**

material:  
cast iron  
finish:  
white enamelled coating



**11.221.B**

material:  
cast iron  
finish:  
black enamelled coating



**11.222**

material:  
304 stainless steel  
finish:  
bright



**11.223**

material:  
304 stainless steel  
finish:  
satin



**11.224.W**

material:  
cast iron  
finish:  
white enamelled coating



**11.224.B**

material:  
cast iron  
finish:  
black enamelled coating



**11.225**

material:  
304 stainless steel  
finish:  
bright



**11.226**

material:  
304 stainless steel  
finish:  
satin

Voltage	110–240V	Noice level	< 78dB
Frequency	50/60Hz	Protection level	IPX1
Total power	2300W	Air temperature(10cm distance/20°C)	60°C
Motor Power	250W	Drying time	15–20s
Consumption	10A	Air Velocity	> 23m/s
Weight	5.9kg	r.p.m.	6200
Electrical Isolation	class I	Automatic disconnection	60 seconds



**11.211**

material:  
cast iron  
finish:  
white enamelled coating



**11.212**

material:  
304 stainless steel  
finish:  
bright



**11.213**

material:  
304 stainless steel  
finish:  
satin



**11.214**

material:  
cast iron  
finish:  
white enamelled coating



**11.215**

material:  
304 stainless steel  
finish:  
bright



**11.216**

material:  
304 stainless steel  
finish:  
satin

Voltage	110–240V	Noise level	<75dB
Frequency	50/60Hz	Protection level	IPX1
Total power	2300W	Air temperature(10cm distance/20°C)	60°C
Motor Power	200W	Drying time	15–20s
Consumption	10A	Air Velocity	22m/s
Weight	4.7kg	r.p.m.	5800
Electrical Isolation	class I	Automatic disconnection	60 seconds

# HAND DRYERS



**11.261**

Material: ABS  
finish: white



**11.262**

material: 304 stainless steel  
finish: bright



**11.263**

material: 304 stainless steel  
finish: satin

Voltage	110–240V	Consumption	7.2A
Frequency	50/60Hz	Air Velocity	> 11m/s
Total power	1650W	Air temperature(10cm distance/20°C)	60°C
Motor Power	60W	Protect Time	60 seconds
r.p.m.	2500	Noice level	< 70dB
Protection level	IPX1	Senser Distance	5–20cm



**11.271**

Material: ABS  
finish: white



**11.272**

material: 304 stainless steel  
finish: bright



**11.273**

material: 304 stainless steel  
finish: satin

Voltage	110–240V	Noice level	< 75dB
Frequency	50/60Hz	Protection level	IPX1
Total power	2100W	Air temperature(10cm distance/20°C)	60°C
Heating element power	1980W	Drying time	25–30s
Motor Power	150W	r.p.m.	5000
Consumption	9.1A	Automatic disconnection	60 seconds
Air Velocity	> 20m/s		



**11.281**

material: cast iron  
finish: white enamelled coating



**11.282**

material: 304 stainless steel  
finish: bright



**11.283**

material: 304 stainless steel  
finish: satin

Voltage	110–240V	Noice level	< 78dB
Frequency	50/60Hz	Protection level	IPX1
Total power	1800W	Air temperature(10cm distance/20°C)	60°C
Heating element power	1200W	Drying time	10–15s
Motor Power	650W	r.p.m.	20000
Consumption	7.8A	Automatic disconnection	60 seconds
Air Velocity	> 85m/s		



**11.291**

material: 304 stainless steel  
finish: satin



**11.301**

Material: ABS  
finish: white



**11.302**

Material: ABS  
finish: white

Voltage	110–240V
Total power	2200W
r.p.m.	6200
Air Velocity	> 20m/s
Senser Distance	5–20cm
Air Temperature (10cm distance)	60°C
Noice level	< 78dB
Drying time	25–30s

Voltage	110–240V
Total power	1200W
r.p.m.	3600
Air Velocity	> 12m/s
Senser Distance	5–20cm
Air Temperature (10cm distance)	60°C
Noice level	< 70dB
Drying time	30–40s

Voltage	110–240V
Total power	1800W
r.p.m.	2800
Air Velocity	> 11m/s
Senser Distance	5–20cm
Air Temperature (10cm distance)	60°C
Noice level	< 70dB
Drying time	30–40s



# 2 IN 1 Tap Hand Dryer



**11.501**

material: 304 stainless steel

finish: satin/black

## FEATURES

- Drying hygienically and quickly
- Touch-free operation
- Energy saving
- Sustainability

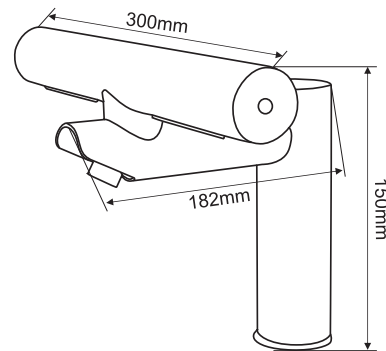

Voltage	110–240V	Protection level	IPX1
Frequency	50/60Hz	Air temperature(10cm distance/20°C)	60°C
Total power	1800W	Drying time	10–15s
Motor Power	550W	Air Velocity	85m/s
Consumption	7.8A	r.p.m.	20000
Noice level	< 78dB	Automatic disconnection	30 seconds
Detection zone	6–25 cm. Preset 15 cm.	Dia. Of inlet pipe	G1/2" (Dn15)or G3/8"(Dn10)